

Model: BPA-RS600-120 Single Output 600W

The **BPA-RS600-120** is a highly reliable, compact, 600W, AC to DC, single output, redundant / removable power supply module. With a full range input of 90-264VAC, this power supply module achieves the highest performance and efficiency by incorporating digital control interleaved PFC and phase-shift full bridge technology. The BPA-RS600 family also includes PMBus™ interface to monitor and control all essential functions of the power supply module.

Custom controls available.



Total Power	Input Voltage	Output Voltage	Minimum	Maximum
600 W	90-264 VAC	12V	0A	50A
		12VSB	0A	1.5A

**Additional Output Configurations Available
12-56VDC**

Special Features

- Compact Size of 50.5 x 40.2 x 245.0 mm
- High efficiency up to 92.0%
- Active Power Factor Correction
- Wide input voltage range: 90 – 264VAC
- Redundant operation
- Hot insertion/removal (hot plug)
- Digital Single wire current sharing
- I²C interface PMBus™ compatible for control, programming and monitoring
- Remote firmware upgrade capable
- Full digital control
- Optional fan airflow direction
- Variable fan speed control
- Series and Parallel Wiring Possible
- Fully secure(OTP, OVP, OCP, SCP)
- LEDs Status :OK, Fault, Warning
- AC OK, DC OK, PS ON, Alert
- CE Compliant
- RoHS Compliant
- Three Year Warranty
- Approved to latest edition of the following Safety Standards: UL/cUL, and DEMKO
- **(To be submitted)**
- **Custom modifications available**

Applications

- High Performance Servers
- Routers
- Switches (POE)
- Telecommunication
- Industrial Application
- SSD High performance RAID products
- High Speed PCIe super computers
- Thunderbolt applications



Phone: 973-594-1800

Salesteam@BluTekPower.com

BPA-RS600-120-Preliminary 07-19-2018

© 2017 BluTek Power, Inc

1. Input Specifications

Parameter	Description/Condition	Min	Nom	Max	Units
$V_{i\ nom}$	Nominal Input Voltage	100		240	VAC
V_i	Input Voltage Ranges	Normal operating (V_{min} to V_{max})		264	VAC
$I_{i\ max}$	Max. Input Current	$V_{in} = 90VAC/60HZ, Full Load$		8.7	A_{rms}
$I_{i\ p}$	Inrush Current	264 $V_{rms}, 25^{\circ}C$		32	A_p
	Leakage Current			0.8	mA
F_i	Input Frequency	47	50/60	63	Hz
PF	Power Factor	$V_{in} = 230V/50Hz$		0.95	W/VA
$V_{i\ on}$	Turn-on Voltage	Ramping Up		89	VAC
$V_{i\ off}$	Turn-off Voltage	Ramping Down		83	VAC
Power _i	Input Power	$V_{in} = 90VAC-264VAC$		750	W
		$V_{in} = 230V, 12V /10A, 12V /0.3A, T_A = 25^{\circ}C$		88	
η	Efficiency without Fan	$V_{in} = 230V, 12V /25A, 12V /0.75A, T_A = 25^{\circ}C$		92	%
		$V_{in} = 230V, 12V /50A, 12V /1.5A, T_A = 25^{\circ}C$		91	
T_{hold}	Hold-up Time			16	ms

1.1 Input Fuse An internal 10A input fuse, in series with the input line, protects against severe defects.

1.2 Inrush Current When the power supply module is connected to the main input, it exhibits a low and short peak current due to an X-capacitance's initial charge. The internal bulk capacitor is charged through a controlled NTC circuit which will limit the inrush current.

1.3 Input Under-Voltage If the input voltage stays below the specified input voltage range for more than 10 seconds the main output will shut down. The power supply module will automatically return to normal operational condition when the input voltage returns to the specified range.

1.4 Power Factor Correction Power factor correction (PFC) is achieved by controlling the input current waveform synchronous with the input voltage. A fully digital controller is implemented giving outstanding PFC results over wide input voltage and load ranges.

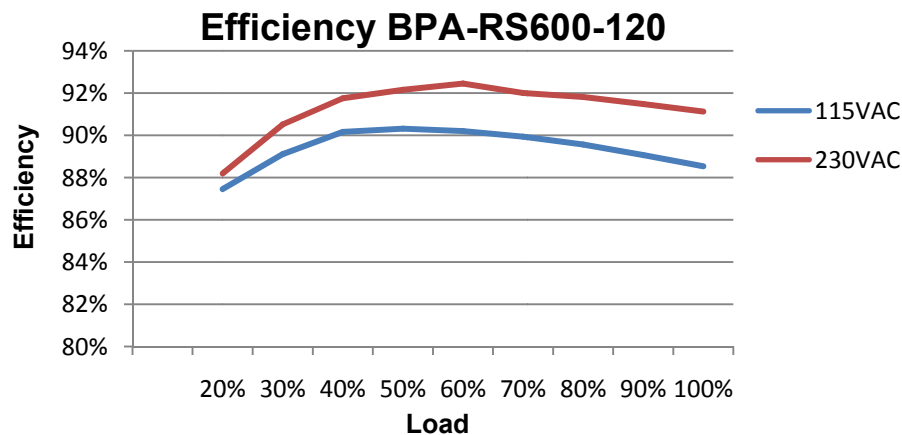

2. Output Specifications

Parameter	Description/Condition	Min	Nom	Max	Units	
Main Output V₁						
V _{1 nom}	Nominal Output Voltage	0.5 · I _{1 nom} , T _{amb} =25°C		12.02	VDC	
V _{1 set}	Output Setpoint Accuracy	0.5 · I _{1 nom} , T _{amb} =25°C		-0.04	0.04	V ₁
P _{1 nom}	Nominal Output Power	V ₁ =12 VDC		600	W	
I _{1 nom}	Nominal Output Current	V ₁ =12 VDC		50	A _{DC}	
V _{1 pp}	Output Ripple Voltage	V _{1 nom} , I _{1 nom} , 20MHz BW		120	mV _{pp}	
dV _{1 Load}	Load Regulation	V _i =V _{i nom} , 0 - 100% I _{1 nom}		-1	1	%V
dV _{1 Line}	Line Regulation	V _i =V _{i min}V _{i max}		-0.2	0.2	%V
dV _{1 tot}	Total Regulation	V _{i min} to V _{i max} , 0 to 100% I _{1 nom} , T _{a min} to T _{a max}		-1	1	%V ₁
dI _{share}	Current Sharing	when Bus load ≥ (20%)		-5%	5%	A
dI _{share}	Current Sharing	when Bus load < (20%)		-10%	10%	A
dV _{dyn}	Dynamic Load Regulation	I _{out} :10%--60% of full load;50--100% of full load		-0.3	0.3	V
T _{rec}	Recovery Time	dI ₁ /dt =1A/μs, recovery within 1% of V _{1 nom}		0.2	1	ms
t _{AC V1}	Start-up Time from AC	Varies with Input Line			3	sec
tV _{1 rise}	Rise Time	V ₁ =10%.....90% V _{1 nom}		100		ms
C _{Load}	Capacitive Loading	T _{amb} =25°C			30000	μF
Standby Output V_{SB}						
V _{SB nom}	Nominal Output Voltage	0.5 · I _{1 nom} , T _{amb} =25°C		12		VDC
V _{SB set}	Output Setpoint Accuracy	0.5 · I _{1 nom} , T _{amb} =25°C		.3	.3	V _{SB}
P _{SB nom}	Nominal Output Power	V _{SB} = 12VDC		18		W
I _{SB nom}	Nominal Output Current	V _{SB} = 12VDC		1.5		A _{DC}
V _{SB pp}	Output Ripple Voltage	V _{SB} , I _{SB} , 20MHz BW		120		mV _{pp}
dV _{SB tot}	Total Regulation	V _{i min} to V _{i max} , 0 to 100% I _{1 nom} , T _{a min} to T _{a max}		-3	3	%V _{SB}
dV _{SB}	Droop	0 - 100% I _{SB nom}			.3	V
dV _{SB dyn}	Dynamic Load Regulation	ΔI _{SB} = 50%, I _{SB nom} , I _{SB} 5.....100% I _{SB nom} ,		-0.3	0.3	%V _{SB}
T _{rec}	Recovery Time	dI ₁ /dt =1A/μs, recovery within 1% of V _{SB nom}			1.2	ms
t _{AC VSB}	Start-up Time from AC	Varies with Input Line		0.2	1.2	sec
tV _{SB rise}	Rise Time	V _{SB} = 10%90% V _{SB nom}		20		ms
C _{Load}	Capacitive Load	T _{amb} =25°C			10000	μF

2.1. Output Voltage Ripple Ripple and noise are measured with 0.1μF of ceramic capacitance and 10 μF of tantalum capacitance on each of the outputs.

3. Protection

Parameter	Description/Condition	Min	Nom	Max	Units
F ₁	Input Fuse	Not user accessible		10	A
V _{1 OV}	Overvoltage Threshold V ₁	13.2		14.4	VDC
t _{OV V1}	Overvoltage Latch Off Time V ₁			1	ms
V _{SB OV}	Overvoltage Threshold V _{SB}	13.2		14.4	VDC
t _{OV VSB}	Overvoltage Latch Off Time V _{SB}			1	ms
I _{V1 lim}	Current Limit	52		55	A
V _{1 SC Max}	Short Circuit Current V ₁	V ₁ < 3V		110	A
t _{V1 SC off}	Short Circuit Latch Off Time	Time to latch off when in short circuit		30	ms
T _{SD}	Over Temperature Protection	Internal temperature		115	°C
	Recovery Temperature			70	°C
I _{VSB lim}	Standby Current Limit	Auto Recovery		3	A

3.1 Overvoltage Protection The power supply module will shut down if the output voltage exceeds the overvoltage threshold. The power supply module must be manually repowered by recycling AC Source, by toggle PS_ON, or PMBus™ operation command.

3.2 Undervoltage Protection The power supply module will shutdown if the output voltage falls below undervoltage threshold (10.8-11.5V). The power supply module must be manually repowered by recycling AC Source, by toggle PS_ON, or PMBus™ operation command.

3.3 Overload Protection* Constant current until the undervoltage threshold point (10.8-11.5V). The power supply will turn off when it falls under the undervoltage threshold on the primary output. The 12V standby utilizes the hiccup method. The power supply module must be manually repowered by recycling AC Source, by toggle PS_ON, or PMBus™ operation command.

3.4 Short-circuit Protection* Latching method on the main output. The 12V standby utilizes the hiccup method. The power supply module must be manually repowered by recycling AC Source, by toggle PS_ON, or PMBus™ operation command.

3.5 Over Temperature Protection The power supply module will shut down if temperature exceeds the over temperature threshold (internal temperature). The power supply module will restart when temperature falls below recovery temperature threshold. The power supply module can also be manually repowered by recycling AC Source, by toggle PS_ON, or PMBus™ operation command.

*For overload and short circuit protection, when the power supply turns on, and there is excessive load, the power supply will remain in constant current for 2sec before shutting off. This is to allow multiple power supplies to turn on in parallel.

4. Safety/Approval

Parameter	Description/Condition	Min	Nom	Max	Units
Agency Approvals	Approved to the latest edition of the following standards: UL/cUL 60950-1 IEC/EN 60950-1		Approved by independent body		
Isolation Strength	Input(L/N) to Case (PE)	1500	Basic		Vrms
	Input (L/N) to Output	3000	Reinforced		Vrms
	Output to Case (PE)	500	Functional		VDC
Electrical Strength Test	Input to Case	2121			VDC
	Input to Output	4242			VDC

Phone: 973-594-1800

Salesteam@BluTekPower.com

5. Electromagnetic Compatibility

5.1 Immunity

Parameter	Description/Condition	Criterion
ESD Contact Discharge	IEC/EN61000-4-2, Level 2 ±4kV	A
Radiated Electromagnetic Field	IEC/EN61000-4-3, Level 2 (3V/m) 80-1000MHz, 1.4-2.0GHz, Level 1 (1V/m) 2.0-2.7GHz	A A
Electrical Fast Transients/ Burst	IEC/EN61000-4-4, level 2 AC port ±1kV, 1 minute	A
Surge	IEC/EN61000-4-5, Level 2 AC port ± 1kV, 1 min CM, Level 3 AC port ±2kV, 1 min CM	A A
RF Conducted Immunity	IEC/EN 61000-4-6, Level 2, 3 V, CW, 0.15 ... 80MHz Amplitude Modulation 1kHz/80%	A
Magnetic Field Immunity	IEC/EN 61000-4-8, Level 2 3A/m	A
Voltage Dips and Interruptions	IEC/EN61000-4-11 1.0% residual voltage, 0.5 cycle 2.0% residual voltage, 1 cycle 3.40% residual voltage, 5 cycles 4.70% residual voltage, 0.5 cycle 5.70% residual voltage, 25 cycles/50Hz 6.0% residual voltage, 250 cycles/50Hz	A B B A B B

5.2 Emission

Parameter	Description/Condition	Criterion
Conducted Emissions	EN 55032 / EN 55016-2-1 conducted	Class A
Radiated Emission	EN 55032 / EN 55016-2-3 radiated	Class A
Harmonics Emission	IEC61000-3-2, $V_{in} = 230VAC/50Hz$, 100% Load	Class A
Acoustical Noise	46dB at 1 meter, 25 C , 50% Load	-
AC Flicker	IEC61000-3-3, $V_{in} = 230VAC/50Hz$, 100% Load, <20Arms	Pass

6. Environmental Specifications

Parameter	Description/Condition	Min	Nom	Max	Units
T _A Ambient Temperature	$V_{i min}$ to $V_{i max}$, $I_{1 nom}$, ISB_{nom}	-20		70*	°C
T _S Storage Temperature	Non- operational	-40		85	°C
Altitude	Operational, above Sea Level		5000 16400		Meter Feet
RH Humidity	Non-condensing	5		95	%
Na Audible Noise	$V_{i nom}$, 50% $I_{o nom}$, $T_a = 25^{\circ}C$		42		dBa

*Derating linearly from 51° -70°C @ 50% load.

*Below 100VAC Derating linearly 46°-70°C @ 50% load.

7. Signals and Controls

7.1 Electrical Characteristics

Parameter		Min	Nom	Max	Unit
PS_ON					
V _{IL}	Input Low Level Voltage	0		0.8	V
V _{IH}	Input High Level Voltage	2.4		3.3	V
R _{puPS_ON}	Internal Pull Up Resistor on PS_ON		10		k Ω
AC_OK/DC_OK/Alert					
V _{IL}	Input Low Level Voltage	0		0.8	V
V _{IH}	Input High Level Voltage	2.4		3.3	V
I _{IL,H}	Maximum Input Sink or Source Current	0		10	mA
R _{puAC_OK}	Internal Pull Up Resistor on AC_OK		none		k Ω
R _{puDC_OK}	Internal Pull Up Resistor on DC_OK		none		k Ω
R _{puAlert}	Internal Pull Up Resistor on Alert		none		k Ω
SCL_1/SDA_1					
V _{IL}	Input Low Level Voltage	0		0.8	V
V _{IH}	Input High Level Voltage	2.4		3.3	V
I _{IL,H}	Maximum Input Sink or Source Current			0.25	mA
R _{puSCL_1}	Internal Pull Up Resistor on SCL_1		3		k Ω
R _{puSDA_1}	Internal Pull Up Resistor on SDA_1		3		k Ω
A0/A1/A2					
V _{IL}	Input Low Level Voltage	0		0.8	V
V _{IH}	Input High Level Voltage	2.4		3.3	V
R _{puA0}	Internal Pull Up Resistor on A0		10		k Ω
R _{puA1}	Internal Pull Up Resistor on A1		10		k Ω
R _{puA2}	Internal Pull Up Resistor on A2		10		k Ω
PS_PRE					
R _{puPS_PRE}	Internal Resistor to COM		0		Ω

7.2 PS_ON The PS_ON signal is used to remotely enable/disable the main output V1 of the front-end. This active-low pin is also used to clear any latched fault condition.

7.3 PS_Present The PS_Present signal is internally connected to COM. This active-low signal is used to indicate to a power distribution unit controller that the power supply module is fully engaged.

7.4 AC_OK The AC_OK is an open collector signal with an active-high when the AC input voltage is above 88VAC and an active-low when the AC voltage falls outside the requirements for more than 10ms.

7.5 DC_OK The DC_OK is an open collector signal with an active-high that indicating whether both VSB and V1 outputs are within regulation. This pin is active-low when V1 and VSB are not within regulation.

7.6 Current Share (12VCS) When used in a redundant configuration, all the current share pins need to be interconnected in order to activate the sharing function. If a supply has an internal fault or is not turned on, the current share line will automatically disengage from the bus.

If current share is not required the current share pin can be left open.

7.7 Remote Sense (+VS and -VS) The main output incorporates sense lines to compensate for voltage drop across the load line.

1. (+) Sense connects to the positive rail of the equipment used. Maximum voltage drop of 200mV.
2. (-) Sense connects to the negative rail of the equipment used. Maximum voltage drop of 200mV.

If remote sense is not required the (+) Sense and (-) Sense pins can be left open.

7.8 Alert Fault/Warning - An open collector signal is provided to indicate any fault or warning such as over temperature, overvoltage, over current, undervoltage, and fan fault.

7.8.1 Front LED

Power Supply Condition	Alert State	Green LED	Yellow LED	AC_OK	DC_OK
Normal Operation	High	On	Off	High	High
Standby Mode	High	Blink	Off	High	Low
PSU Faults Condition					
Input Undervoltage	Low	Off	On	Low	Low
Output Overvoltage	Low	Off	On	High	Low
Fan	Low	Off	On	High	Low
Over Temperature	Low	Off	On	High	Low
Output Over Current	Low	Off	On	High	Low
PSU Warning Condition					
Over Temperature	Low	On	Blink	High	High
Fan Speed(Low Speed)	Low	On	Blink	High	High
Output Over Current	Low	On	Blink	High	High
Input Undervoltage	Low	On	Blink	Low	High

See Page 4 (3. Protections) for fault Threshold.

For Faults the power supply module must be manually repowered by recycling AC Source, by toggle PS_ON, or PMBus™ operation command.

7.8.2 Warnings

PSU Warning Triggers	Min	Nom	Max	Units
Over Temperature		115		°C
Fan Speed(Low RPM)	2400	2500	2600	RPM
Output Over Current		52		A
Input Undervoltage		85		VAC

7.9 SDA & SCL The I2C bus consist of a Serial Clock (SCL) and a Serial Data Line (SDA). Both signals lines are pull up internally to 3.3V bus via 6.8k ohm resistors, if customer requires stronger pull up resistors, it is possible to install additional pull up resistors in the customer’s backplane.

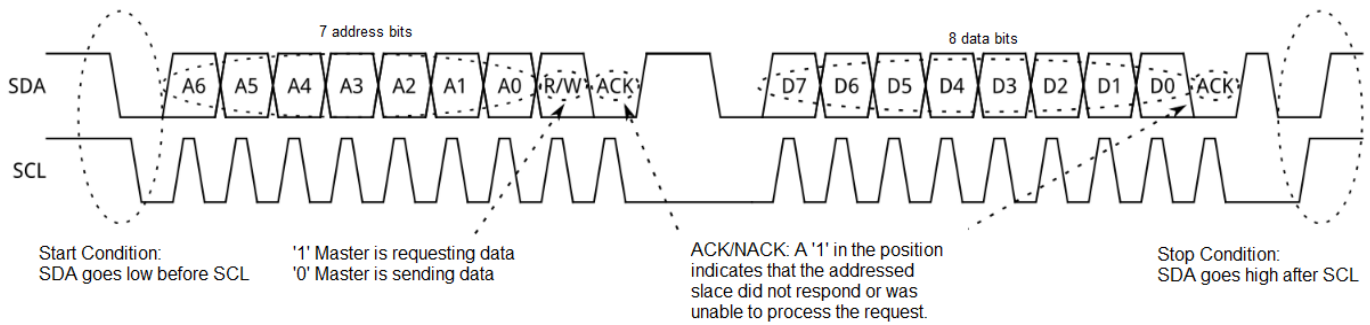

7.10 Address Select (A0, A1, A2) These digital input lines are used to set the address of the power supply module. These addresses are used to differentiate between multiple power supply modules utilize in a redundant mode within the same system.

7.11 PSU Address Table (Address Bit Settings)

A0, A1, & A2	PSU Address Value	A2	A1	A0	Recognize Address
00h	B0h	0	0	0	Yes
01h	B2h	0	0	1	Yes
02h	B4h	0	1	0	Yes
03h	B6h	0	1	1	Yes
04h	B8h	1	0	0	Yes
05h	BAh	1	0	1	Yes
06h	BCh	1	1	0	Yes
07h	BEh	1	1	1	Yes

7.12 Timing Graph

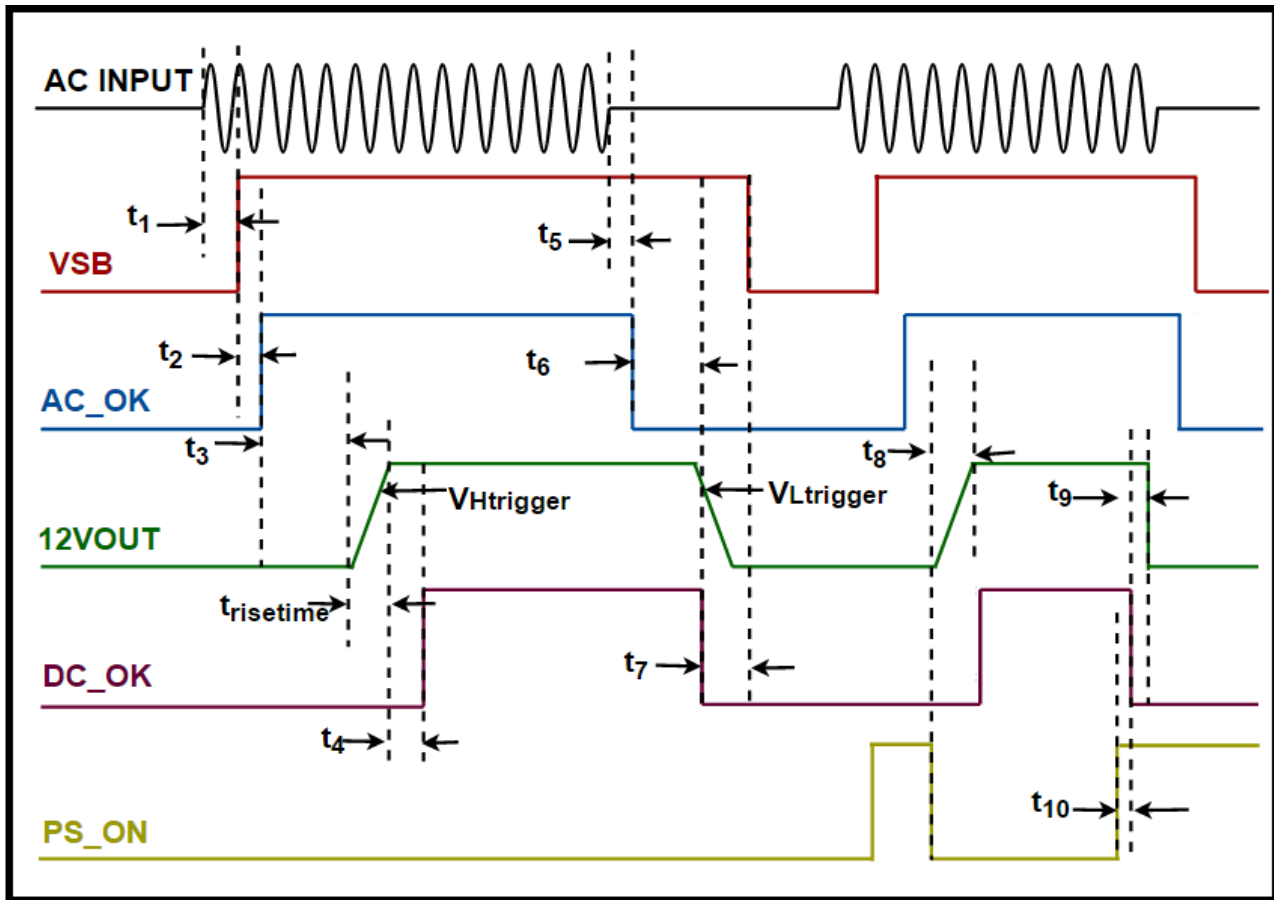

Parameter	Description/Condition	Min	Nom	Max	Unit	
t _{risetime}	12VOUT, 0V to 12V	80	100	120	ms	
V _{Htrigger}	DCOK(high)	Varies due to Load	11.5	-	11.8	V
V _{Ltrigger}	DCOK(low)	Varies due to Load	10.8	11.2	11.5	V
Turn-On						
t ₁	AC INPUT - VSB	Varies due to Line and Load	200	Varies	1200	ms
t ₂	VSB - AC_OK		-	230	300	ms
t ₃	AC_OK - 12VOUT	Varies due to Line and Load	.4		1	s
t ₄	12VOUT - DC_OK		120	-	200	ms
t ₈	PS_ON(low) - 12VOUT	PS_ON Turn-On	.8	-	1.5	s
Turn-Off						
t ₅	AC INPUT - AC_OK	AC IN Turn-Off	10	-	-	ms
t ₆	AC_OK - DC_OK	AC IN Turn-Off Varies due to Load	7	-	-	ms
t ₇	DC_OK - VSB	AC IN Turn-Off Varies due to Line and Load	180	-	-	ms
t ₉	DC_OK - 12VOUT	PS_ON Turn-Off	400	440	480	µs
t ₁₀	PS_ON(high) - DC_OK(low)	PS_ON Turn-Off	-	10	-	ms

Phone: 973-594-1800

Salesteam@BluTekPower.com

7.13 PMBus™ Functionality Supported By PSU (PMBus™ Info)

Address	Commands	Description	Supported	Transaction-Type	Byte_Size
01h	Operation_ON_OFF	Used to enable or disable the output of the PSU depending value of the second byte that follows.	Y	Read/Write	2-bytes
03h	Clear_Fault	Used to clear all status registers and error flags. This command also affects the SMB_ALERT signal.	Y	Write Only	1-byte
19h	Capability	Used by the end user system to query the PSU, to determine if it supports certain features, or not. Features such packet error checking, SMB_ALERT and the max SMBUS clock rate.	Y	Read Only	1-byte
20h	VOUT_Mode	Sets/reads the formats (Linear, VID, and Direct) and exponents for VOUT related commands.	Y	Read Only	1-byte
3Bh	Fan_Command_1	Used by the end user system to override the fan speed versus temperature algorithm of the PSU, so that the system can set the fan speed to where ever it requires within the limits of the fan specification.	Y	Read/Write	2-bytes
78h	Status_Byte	Used to retrieve and report one byte containing a summary of the most critical faults. All bits in this register should read as zero when the PSU is operating normally.	Y	Read/Write	1-byte
79h	Status_Word	Used to retrieve and report two bytes containing a summary of faults conditions. All bits in this register should read as zero when the PSU is operating normally. This register acts as an index to all the other status registers.	Y	Read/Write	2-bytes
7Ah	Status_VOUT	Used to retrieve and report the status of the output voltages. It reports information such as output under-voltage, output over-voltage, output under voltage-warning	Y	Read/Write	1-byte
7Bh	Status_IOUT	Used to retrieve and report the status of the device output current. It relays information, such as output over current conditions, exceeded and output current approaching it maximum rating.	Y	Read/Write	1-byte
7Ch	Status_INPUT	Used to retrieve and report the status of the device input. It relays information, such as input over current, input over power, input OVP rating exceeded and input current approaching it maximum rating.	Y	Read/Write	1-byte

7.13 PMBus™ Functionality Supported By PSU (PMBus™ Info) - Continued

Address	Commands	Description	Supported	Transaction-Type	Byte_Size
7Dh	Status_Temperature	Used to retrieve and report the status of the device operating temperatures both ambient and heat-sinks.	Y	Read/Write	1-byte
7Eh	Status_CML	Used to retrieve and report the status of the I2C or SMBUS communication bus; error such as packet error checking (PEC), receive an unsupported command etc...	Y	Read/Write	1-byte
81h	Status_Fans_1&2	Used to retrieve and report the operating status of fan_1 & 2.	Y	Read/Write	1-byte
88h	Read_VIN	Used to retrieve a two bytes value in Little Endian format representing the active input voltage of the device in a linear format ($VIN = Y \cdot 2^n$), where n is the exponent in two's complement represented by the five most significant bits of the upper byte. Y is the mantissa represented the eleven lower bits of the two byte word.	Y	Read Only	2-bytes
89h	Read_IIN	Used to retrieve a two bytes value in Little Endian format representing the active input current of the device in a linear format ($IIN = Y \cdot 2^n$), where n is the exponent in two's complement represented by the five most significant bits of the upper byte. Y is the mantissa represented the eleven lower bits of the two byte word.	Y	Read Only	2-bytes
97h	Read_PIN	Used to retrieve a two bytes value in Little Endian format representing the active input power of the device in a linear format ($PIN = Y \cdot 2^n$), where n is the exponent in two's complement represented by the five most significant bits of the upper byte. Y is the mantissa represented by the eleven lower bits of the two byte word.	Y	Read Only	2-bytes
8Bh	Read_VOUT	Used to retrieve a two bytes value in Little Endian format representing the active output voltage of the device in a linear format ($VOUT = Y \cdot 2^9$), VOUT is a special case where the mantissa and the exponent are not combined, but listed separately.	Y	Read Only	2-bytes
D1h	Standby_VOUT	Used to retrieve a two bytes value in Little Endian format representing the standby output voltage of the device in a linear format ($Standby_VOUT = Y \cdot 2^9$), VOUT is a special case where the mantissa and the exponent are not combined, but listed separately.	Y	Read Only	2-bytes

7.13 PMBus™ Functionality Supported By PSU (PMBus™ Info) - Continued

Address	Commands	Description	Supported	Transaction-Type	Byte_Size
8Ch	Read_IOUT	Used to retrieve a two bytes value in Little Endian format representing the active output current of the device in a linear format ($IOUT = Y \cdot 2^n$), where n is the exponent in two's complement represented by the five most significant bits of the upper byte. Y is the mantissa represented the eleven lower bits of the two byte word.	Y	Read Only	2-bytes
D0h	Standby_IOUT	Used to retrieve a two bytes value in Little Endian format representing the standby output current of the device in a linear format ($Standby_IOUT = Y \cdot 2^n$), where n is the exponent in two's complement represented by the five most significant bits of the upper byte. Y is the mantissa represented the eleven lower bits of the two byte word.	Y	Read Only	2-bytes
96h	Read_POUT	Used to retrieve a two bytes value in Little Endian format representing the active output power of the device in a linear format ($POUT = Y \cdot 2^n$), where n is the exponent in two's complement format, represented by the five most significant bits of the upper byte. Y is the mantissa represented by the eleven lower bits of the two byte word.	Y	Read Only	2-bytes
D5h	StandBy_POUT	Used to retrieve a two bytes value in Little Endian format representing the standby output power of the device in a linear format ($StandBy_POUT = Y \cdot 2^n$), where n is the exponent in two's complement format, represented by the five most significant bits of the upper byte. Y is the mantissa represented by the eleven lower bits of the two byte word.	Y	Read Only	2-bytes
98h	PMBus™_Revision	Used to set and retrieve the version of the PMBus™ specification, with which the PSU is in compliance.	Y	Read Only	1-byte
9Ah	MFR_Model	Used to set and retrieve the manufacturer's model number assign to the device.	Y	Read/Write	Variable plus 1-byte count
9Bh	MFR_Revision	Used to set and retrieve the manufacturer's revision of the device.	Y	Read/Write	1-byte
9Ch	MFR_Location	Used to set and retrieve the location of manufacturing of the device.	Y	Read/Write	Variable plus 1-byte count
9Dh	MFR_Date	Used to set and retrieve the date of manufacturing of the device.	Y	Read/Write	4-bytes plus 1byte count

Address	Commands	Description	Supported	Transaction-Type	Byte_Size
9Eh	MFR_Serial	Used to set and retrieve the value of the manufacturer's serial number assigned to the device.	Y	Read/Write	Variable plus 1-byte count
A0h	MFR_VIN_MIN	Used to retrieve the value of the minimum rated input voltage, that the PSU can be operated. Also, utilizes the Little Endian format where the two's compliment exponent is ($VIN_MIN = Y * 2^1$).	Y	Read Only	2-bytes
A1h	MFR_VIN_MAX	Used to retrieve the value of the maximum rated input voltage, that the PSU can be operated safely. Also, utilizes the Little Endian format where the two's compliment exponent is ($VIN_MAX = Y * 2^1$).	Y	Read Only	2-bytes
A2h	MFR_IIN_MAX	Used to retrieve the value of the maximum rated input current in Amps, that the PSU can be operated. Also, utilizes the Little Endian format where the two's compliment exponent is ($IIN_MAX = Y * 2^6$).	Y	Read Only	2-bytes
A3h	MFR_PIN_MAX	Used to retrieve the value of the maximum rated output power in Watts, that the PSU can be operated. Also, utilizes the Little Endian format where the two's compliment exponent is ($PIN_MAX = Y * 2^1$).	Y	Read Only	2-bytes
A4h	MFR_VOUT_MIN	Used to retrieve the value of the minimum rated output voltage that the PSU can provide. Also utilizes the Little Endian format where the two's compliment exponent is ($VOUT_MIN = Y * 2^9$).	Y	Read Only	2-bytes
A5h	MFR_VOUT_MAX	Used to retrieve the value of the maximum rated output voltage that the PSU can provide. Also utilizes the Little Endian format where the two's compliment exponent is ($VOUT_MAX = Y * 2^9$).	Y	Read Only	2-bytes
A6h	MFR_IOUT_MAX	Used to retrieve the value of the maximum rated output current in Amps, that the PSU is expected to provide. Also, utilizes the Little Endian format where the two's compliment exponent is ($IOUT_MAX = Y * 2^4$).	Y	Read Only	2-bytes
A7h	MFR_POOUT_MAX	Used to retrieve the value of the maximum rated output power in Watts, that the PSU is expected provide. Also, utilizes the Little Endian format where the two's compliment exponent is ($POOUT_MAX = Y * 2^1$).	Y	Read Only	2-bytes
A8h	MFR_TAMBIENT_MAX	Used to retrieve the value of the maximum ambient temperature that the PSU can be operated, in degree Celsius. Also, utilizes the Little Endian format where the two's compliment exponent is ($TAMBIENT_MAX = Y * 2^2$).	Y	Read Only	2-bytes
A9h	MFR_TAMBIENT_MIN	Used to retrieve the value of the minimum ambient temperature that the PSU can be operated, in degree Celsius. Also, utilizes the Little Endian format where the two's compliment exponent is ($TAMBIENT_MIN = Y * 2^2$).	Y	Read Only	2-bytes

7.13 PMBus™ Functionality Supported By PSU (PMBus™ Info) - Continued

Address	Commands	Description	Supported	Transaction-Type	Byte_Size
8Dh	Read_Temperature_1	Used to retrieve a two bytes value in Little Endian format representing the ambient temperature of the device in a linear format ($Temp_1 = Y*2^n$), where n is the exponent in two's compliment format, represented by the five most significant bits of the upper byte. Y is the mantissa represented by the eleven lower bits of the two byte word. Reads the ambient temperature around the input connector.	Y	Read Only	2-bytes
8Eh	Read_Temperature_2	Used to retrieve a two bytes value in Little Endian format representing the ambient temperature of the device in a linear format ($Temp_2 = Y*2^n$), where n is the exponent in two's compliment format, represented by the five most significant bits of the upper byte. Y is the mantissa represented by the eleven lower bits of the two byte word. Reads the ambient temperature around the output connector.	Y	Read Only	2-bytes
DAh	Read_Temperature_3	Used to retrieve a two bytes value in Little Endian format representing the component temperature of the device in a linear format ($Temp_3 = Y*2^n$), where n is the exponent in two's compliment format, represented by the five most significant bits of the upper byte. Y is the mantissa represented by the eleven lower bits of the two byte word. Reads the temperature of PFC FETS.	Y	Read Only	2-bytes
DBh	Read_Temperature_4	Used to retrieve a two bytes value in Little Endian format representing the component temperature of the device in a linear format ($Temp_3 = Y*2^n$), where n is the exponent in two's compliment format, represented by the five most significant bits of the upper byte. Y is the mantissa represented by the eleven lower bits of the two byte word. Reads the temperature of Output FETS.	Y	Read Only	2-bytes
90h	Read_Fan_Speed_1	Used to retrieve a two bytes value in Little Endian format representing the fan_1 speed of the device in a linear format ($Fan_Speed_1 = Y*2^n$), where n is the exponent in two's compliment format, represented by the five most significant bits of the upper byte. Y is the mantissa represented by the eleven lower bits of the two byte word.	Y	Read Only	2-bytes

8. PMBus™ Monitoring

Parameter	Description/Condition	Min	Nom	Max	Units
V _{i mon}	Input RMS Voltage $V_{i min} \leq V_i \leq V_{i max}$	-3.5		3.5	%
I _{i mon}	Input RMS Current	-2		2	%
P _{i mon}	Input Power	-4		4	%
V _{1 mon}	V1 Voltage	-0.5		0.5	%
I _{1 mon}	V1 Current	-2		-2	%
P _{o nom}	Total Output Power	-1.5		-1.5	%
V _{SB mon}	Standby Voltage	-2		2	%
I _{SB mon}	Standby Current I _{STBY} >1A increase the percent error of the reading	-15		15	%
t ₁	Temperature1 Input Connector	-2		2	°C
t ₂	Temperature2 Output Connector	-2		2	°C
t ₃	Temperature3 Primary Section	-2		2	°C
t ₄	Temperature4 Secondary Section	-2		2	°C
F _S	Fan Speed Measurement Accuracy	-5		5	%
	Fan Speed Control Range(0-23000RPM)	0		100	%

9. Temperature and Fan Control

Fan Speed	RPM
Nominal Fan Speed (Fan will start to speed up when the internal power supply module temperature exceeds 50°C)	8000 RPM
Maximum Fan Speed (Fan will reach its maximum speed of 23000 RPM when the internal power supply module temperature reaches 80°C.)	23000 RPM
Minimum Warning Fan Speed	2500 RPM

9.1 Fan Airflow To achieve the best cooling results, sufficient airflow through the supply must be maintained. Do not block or obstruct the airflow on either side of the power supply.

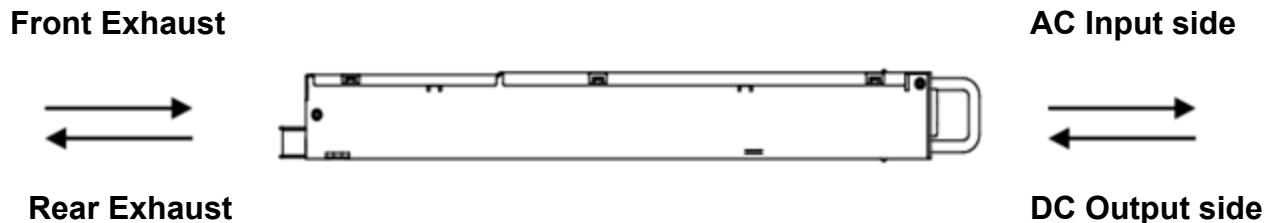

Normal (Rear Exhaust) and reverse (Front Exhaust) airflow options are available. See ordering Information for details.

10. Connection

10.1 Connectors

Input ----- IEC320

Output ----- FCI P/N 10127397-23H1400



P1	P2	P3	P4	1	2	3	4	5	6	T	S	R
VO1_PWR	VO1_PWR	VO1_RTN	VO1_RTN	12VS(+)	NU	12VSB	COM	A2	A1			
				12VS(-)	NU	PS_PRE	DC_OK	AC_OK	Alert			
				12VCS	NU	PS_ON	SDA_1	A0	SCL_1			

Note: 1T, 1R, 3S and 3R are short pins

Pins	Pin Type	Assignment	Description/Function
Output			
P1, P2	Power	VO1_PWR	These are the +12 voltage output pins.
P3, P4	Power	VO1_RTN	These are the 12V return output pins.
Control			
1T	Signal	12VS(+)	(+) Sense - If remote sense is required this pin must be connected to the +12V load on the system backplane. This pin can be left open if remote sense is not required.
1S	Signal	12VS(-)	(-) Sense - If remote sense is required this pin must be connected to the 12V return on the system backplane. This pin can be left open if remote sense is not required.
1R	Signal	12VCS	Current Share - This pin must be connected to the 12V current share of the redundant power supplies on the system backplane. This pin can be left open if current share is not required.
3T	Signal House Keeping	12VSB	12V Stand by - This is the 12V standby output voltage pin.
3S	Signal	PS_PRE	Power Supply Present - This signal is connected to the common internally. This signal is used to identify that the power supply module is fully plugged into the system backplane
3R	Signal	PS_ON	Power Supply On - This is the power supply module control pin. This pin must be directly connected to common or controlled by a transistor connected to common on the system backplane.
4T	Signal	COM	Common - This is the common return pin for the power supply module.
4S	Signal Open Collector	DC_OK	DC Okay - This pin is used to monitor the output voltage. The signal on this pin will go high 100 to 150mSecs after the 12V output has reached regulation (above 11.5V). This signal will go low when the output voltage drops out of regulation (10.8V-11.5V). This pin must be connected to an external voltage via pull up resistor on the system backplane 20V max 10mA max.
6S	Signal Open Collector	ALERT	Fault/Warning - An open collector signal is provided to indicate any fault or warning such as over temperature, overvoltage, over current, undervoltage, and fan fault.
5S	Signal Open Collector	AC_OK	AC Okay - This pin is used to monitor the AC input voltage. The signal on this pin will go high when the AC input voltage is above 88VAC. When the AC input voltage drops below 88VAC this signal will go low a minimum of 10mSec before the output voltage drops out of regulation. This pin must be connected to an external voltage via pull up resistor on the system backplane 20V max 10mA max.
4R	Signal	SDA_1	Communication Data pin internal pulled up by a 3k Ω resistor.
6R	Signal	SCL_1	Communication Clock pin internal pulled up by a 3k Ω resistor.
5R	Signal	A0	Address Pin-This pin operates at 3.3V internal pulled up by a 10k Ω resistor.
6T	Signal	A1	Address Pin-This pin operates at 3.3V internal pulled up by a 10k Ω resistor.
5T	Signal	A2	Address Pin-This pin operates at 3.3V internal pulled up by a 10k Ω resistor.

Phone: 973-594-1800

Salesteam@BluTekPower.com

10.2 Parallel Wiring Diagram

Dash lines show remote sense connections.

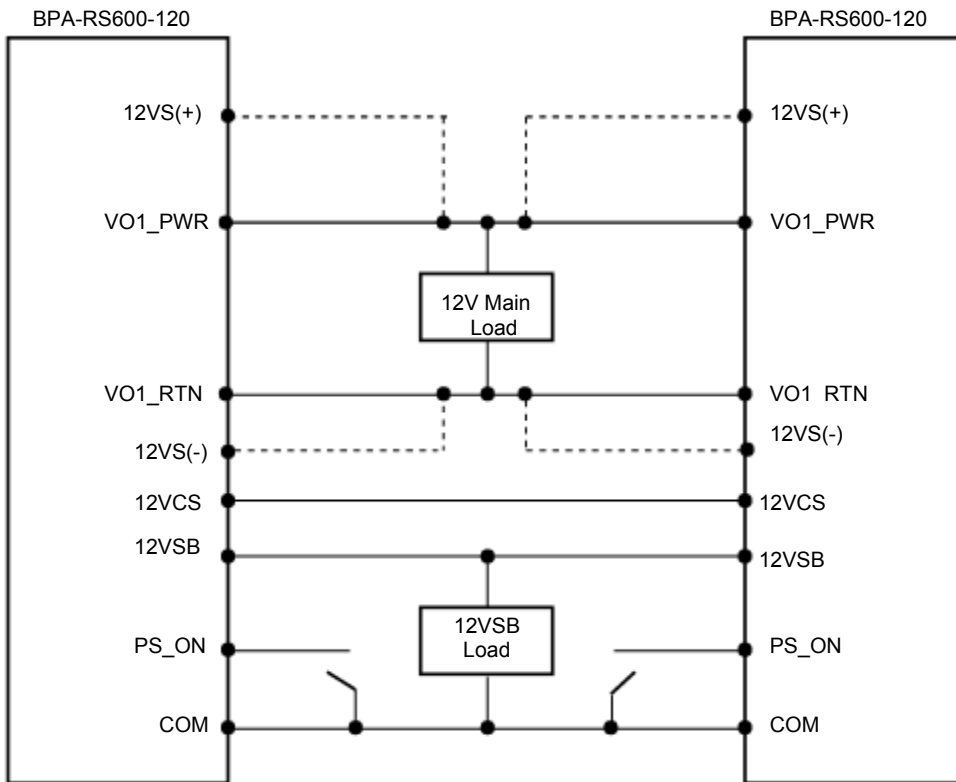

10.3 Series Wiring Diagram (Requires Isolation on Main Output)*

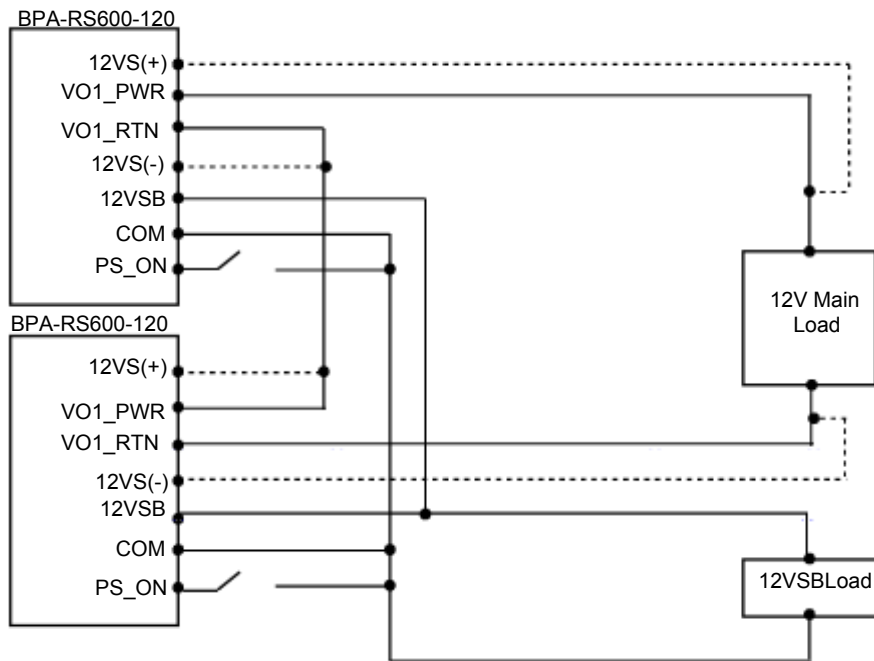

When operating in series the current share pin must be left open.
 *Look at Ordering Information on last page.

Phone: 973-594-1800
Salesteam@BluTekPower.com

11. Mechanical

Parameter	Description/Condition	Min	Nom	Max	Units
Dimension	Width		50.5(1.99)		mm(in)
	Height		40.2(1.58)		
	Depth		245(9.65)		
Weight			0.7(1.5)		Kg(lbs)

Mechanical 3D Model Available

Top View

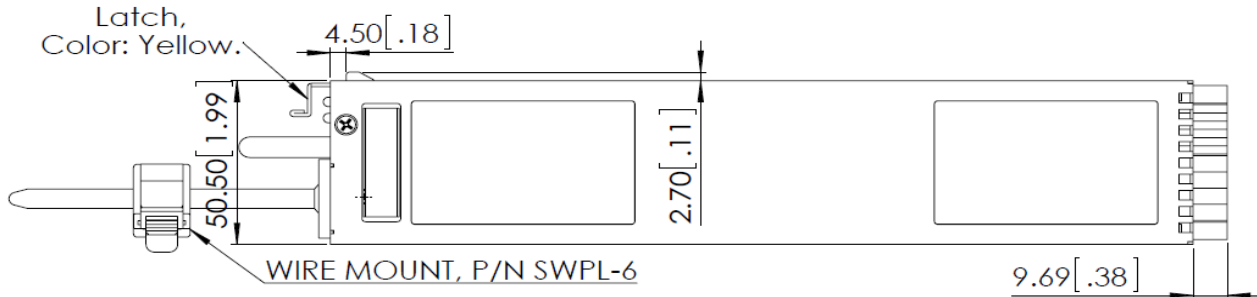

Bottom View

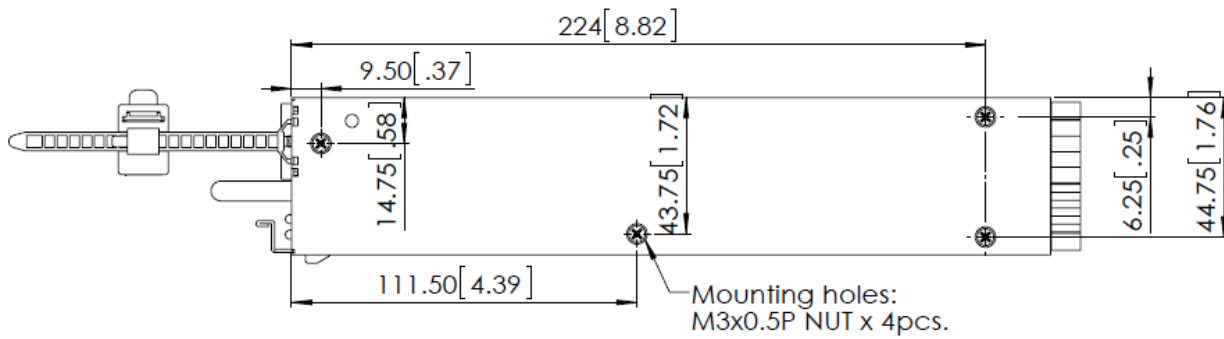

Side Views

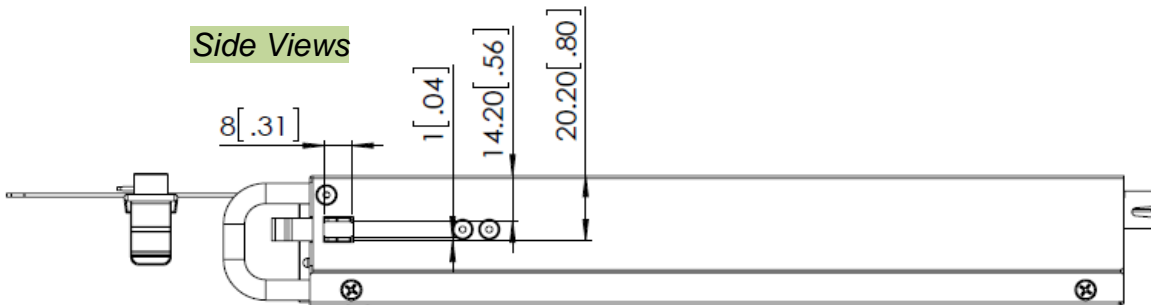

Front View

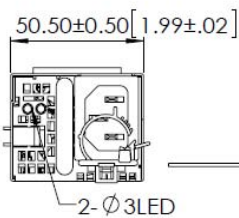

Rear View

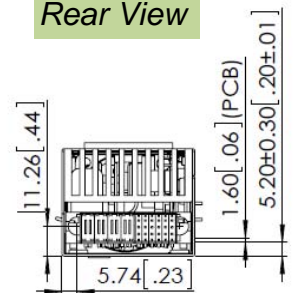

Phone: 973-594-1800
Salesteam@BluTekPower.com

12. Ordering Information

Model number matrix for BPA-RS600-XXX-YY

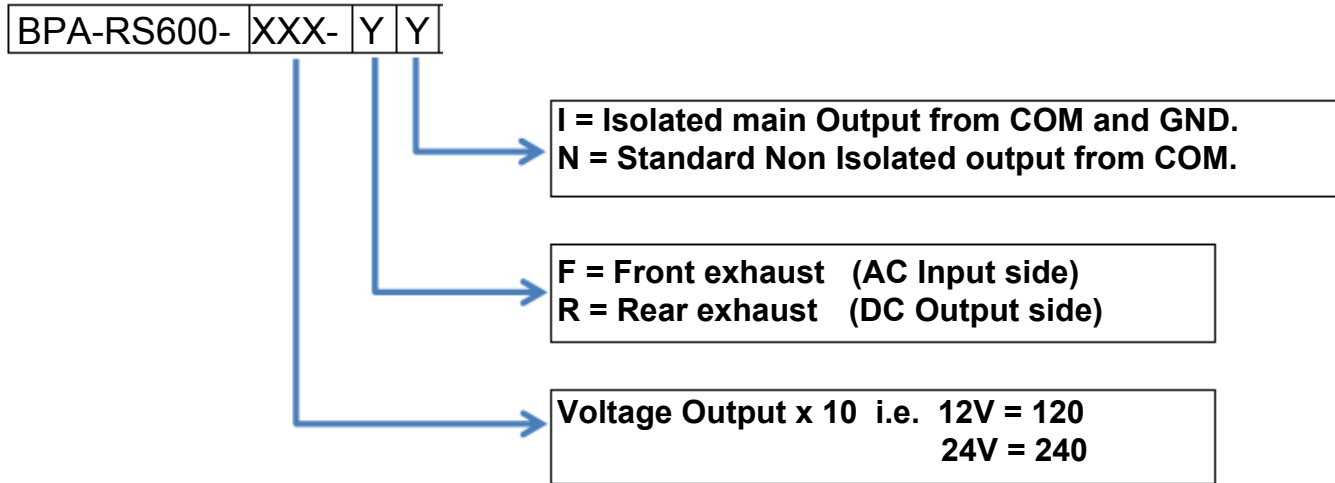

Technical Revisions – The appearance of products, including safety agency certification pictured on labels, may change depending on the date manufactured. Specifications are subject to change without notice.

Custom Modifications and Voltages are Available

MODEL No. / OUTPUT VOLTAGE / CURRENT RATINGS CHART

<i>Model No.</i>	<i>O/P Voltage (Vdc)</i>	<i>Minimum</i>	<i>Maximum</i>
BPA-RS600-120	12V	0A	50A
	12VSB	0A	1.5A
BPA-RS600-240	24V	0A	25A
	12VSB	0A	1.5A
BPA-RS600-480	48V	0A	12.5A
	12VSB	0A	1.5A
BPA-RS600-560	56V	0A	10.7A
	12VSB	0A	1.5A

Contact Info:

Address: 300-1 Route 17 South Suite B2 Lodi, NJ 07644 USA
 Phone: 973-594-1800
 Email: Salesteam@BluTekPower.com

For more information on these products please contact a BluTek Sale Representative.